

No.	NAME	MATERIAL	DWG/MATL No.	CODE	Q'TY	SIZE	WEIGHT	REMARK
-----	------	----------	--------------	------	------	------	--------	--------

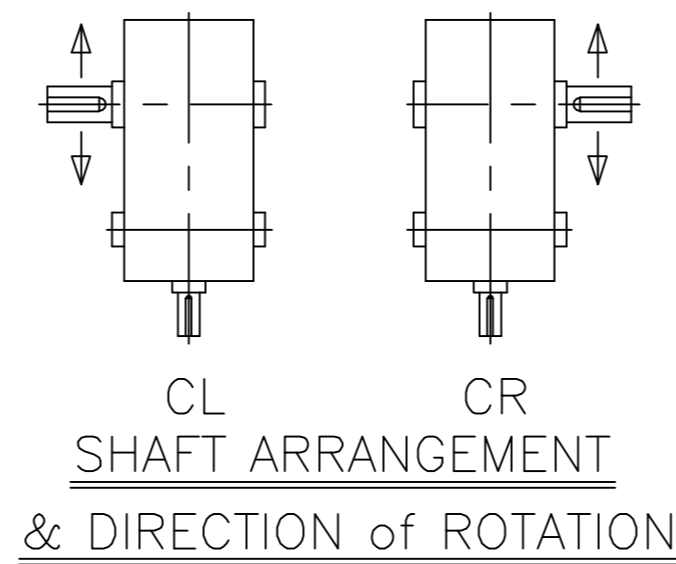
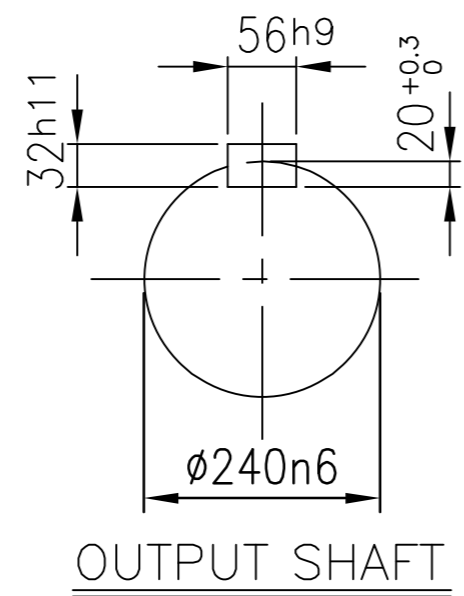
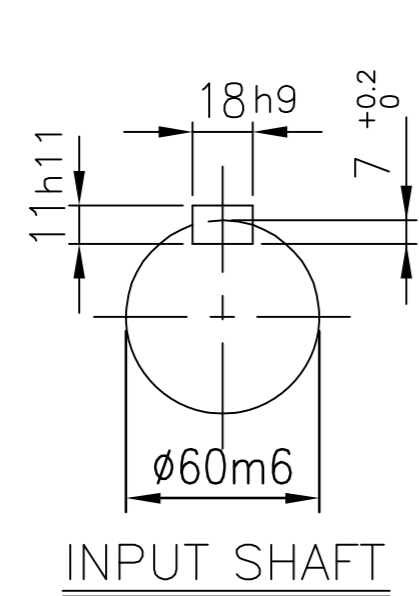
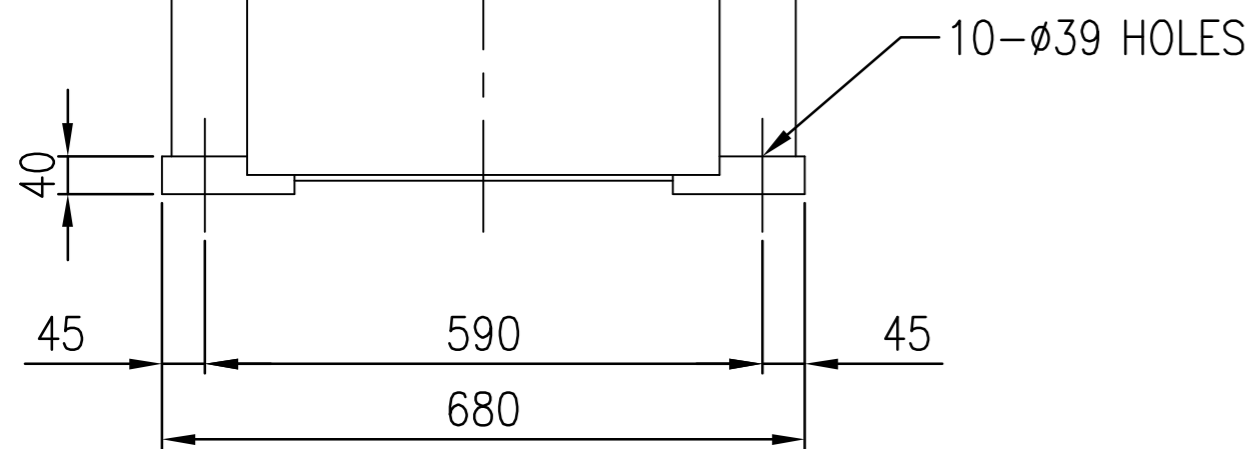
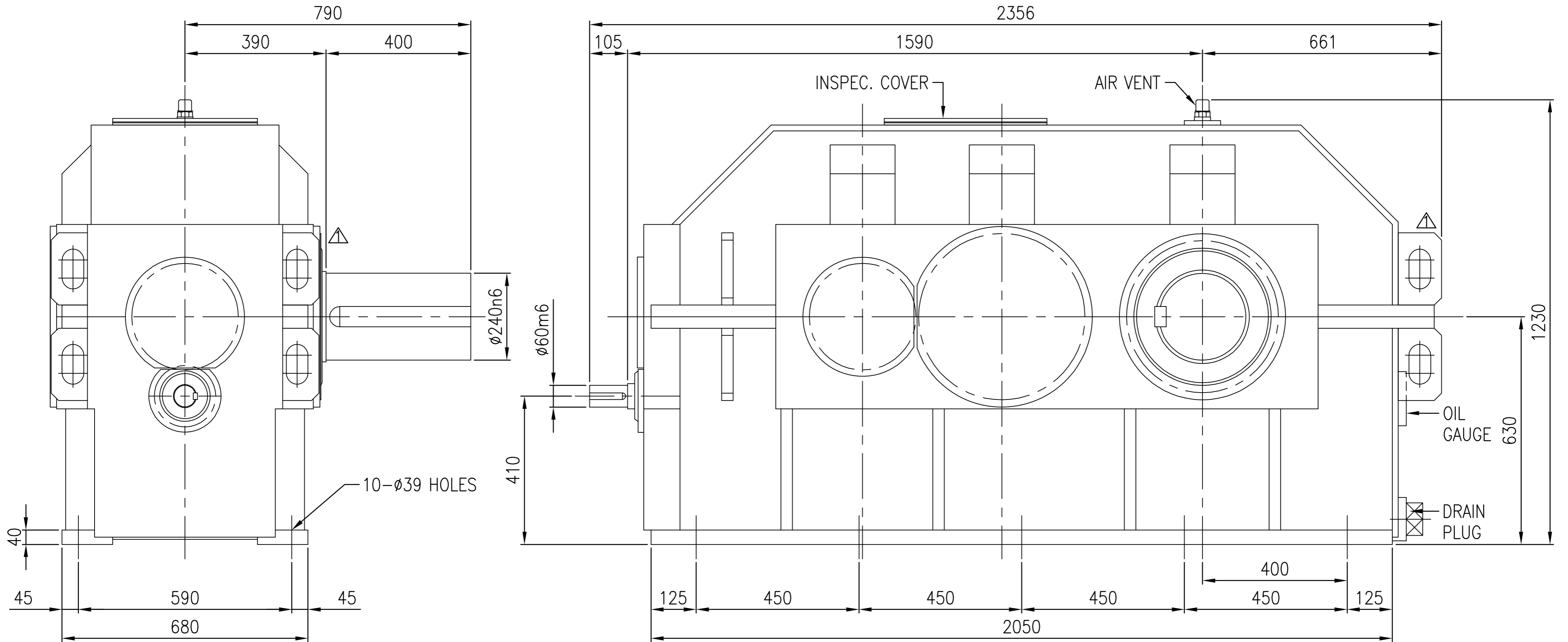

DWG NAME		기어박스 외형도			
DIMENSION		DIMENSION			
2013.09.27	CHANGED LIFTING LUG	DWG No. <b>EK1DO00214</b>		UNIT	mm
No.	DATE	DESIGNED	CHECKED	REVIEWED	APPROVED
		박선향	서성민		김기동
FORM CE-14-0100-4A2 2012.02.08		HYOSUNG		REVISION NO.	01
ITEM SKD56 (i=80~200)		REF. NO.		DSKEN655	(A)