

INPUT SHAFT

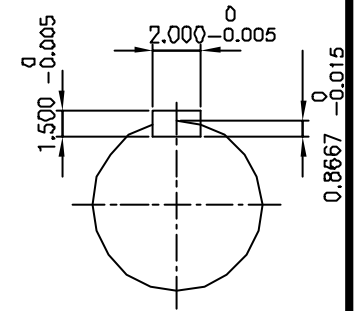

OUTPUT SHAFT

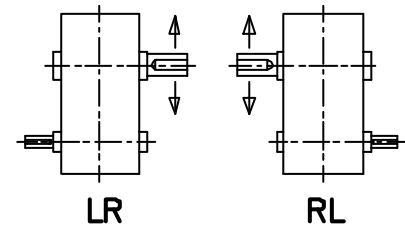

SHAFT ARRANGEMENT & DIRECTION of ROTATION

REV	DESCRIPTION	APPR	CHCK	DRWN	DATE
△					
△					
△					
△					
△					

TYPE				DWG. NAME			
SHB 50 (i = 25 ~ 28)				DIMENSION			
APPROV	CHECK	DESIGN	DRAWN	THIRD ANGLE PROJECTION	SCALE	1/14	DATE 1998.11.26.
L.H.Y	M.B.U	J.J.K		REF DWG NO.			
HYOSUNG CORPORATION				DWG NO.	S K E N 5 4 8		