

NOTE

| | LOW SPEED | HIGH SPEED |
|-----------------|----------------------------------|------------|
| 1. MOTOR POWER | 400 kW | |
| 2. INPUT RPM | 1120 RPM | |
| 3. OUTPUT RPM | 41,948 RPM | 84,211 RPM |
| 4. TOTAL RATIO | 1/26.7 | 1/13.3 |
| 5. OIL CAPACITY | ISO VG #220 (APPROX. 250 LITERS) | |
| 6. TOTAL WEIGHT | 5300KG (APPROX.) | |

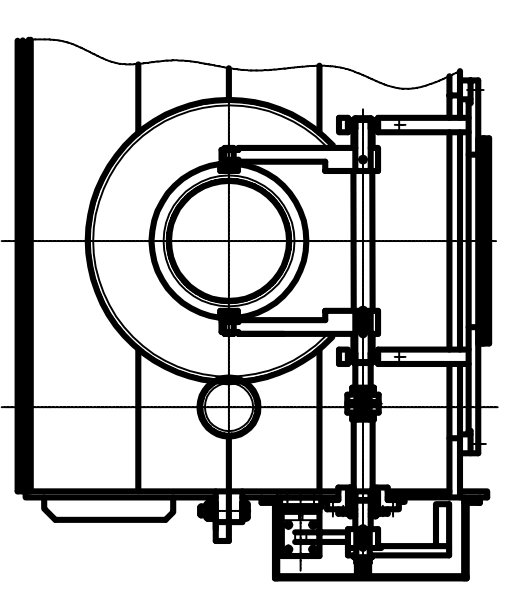
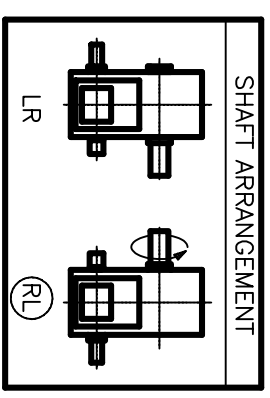

| REV | DESCRIPTION | APPROVAL | DATE |
|-----|-------------|----------|------|
| | | | |
| | | | |
| | | | |
| | | | |

| | | | |
|--------------------|----------------------|------------------------|-------------|
| TYPE | SHB56-SC | DWG. NAME | DIM & ASS'Y |
| APPROVAL | CHECK DESIGN DRAWING | THIRD ANGLE PROJECTION | SCALE 1 |
| DATE | 2006.01.23 | DATE | 2006.01.23 |
| HOSUNG CORPORATION | | | |
| DWG NO. | S K C 8 9 4 7 | | |