

**OUTPUT SHAFT**

KEY 12 x 8 x 57

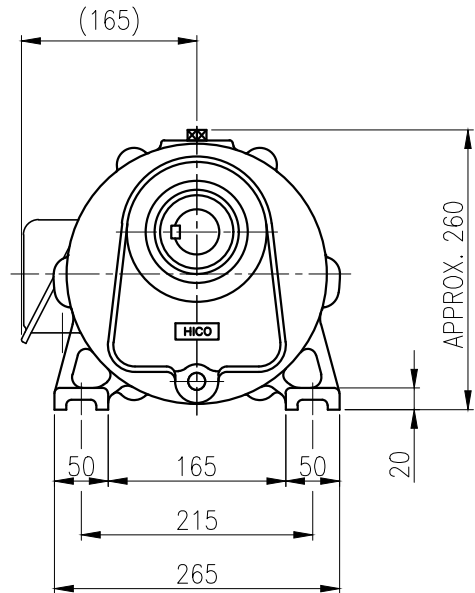
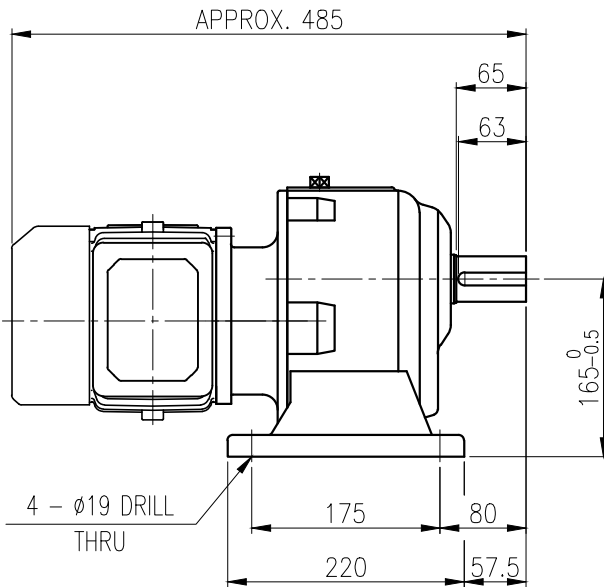

		BEARING			
		INPUT SHAFT	#6203ZZ	#6205ZZ	
OIL SEAL		2ND PINION	#6302ZZ	#6303ZZ	GREASE : NLGI(EP)00
MOTOR SHAFT	D(M) 18x30x8	3RD PINION	#6303ZZ	#6305ZZ	ABOUT 0.8 kg
OUTPUT SHAFT	D(M) 45x68x12	OUTPUT SHAFT	#6309ZZ	#PM3020	WEIGHT 55 kg

		DWG NAME 외형도 OUTKUNE DIMENSION			
		DWG No. EK2D007105H0001		UNIT mm	
				SCALE 1:1	
No.	DATE	DESCRIPTION of REVISION			
A4(210x297mm)	FORM CE-14-0100-444 2013.11.20				
TYPE RPH_80Fr(0.75kW)_100~120:1_N type					
DESIGNED	CHECKED	REVIEWED	APPROVED	DATE	2018-08-15
2018.10.01	2018.10.01	2018.10.01	2018.10.01	REVISION No.	01
최성민	문병선	박희성	홍원철	THIRD ANGLE PROJECTION	
REF. No.	(EN273)				(A)

이 도면상에 표시된 정보는 표상용(단)의 소유이며 영사의 사전 서면동의 없이 무단사용을 금합니다.