

1	2	3	4	5				
No.	NAME	MATERIAL	DWG/MATL No.	CODE	Q'TY	SIZE	WEIGHT	REMARK
					0			

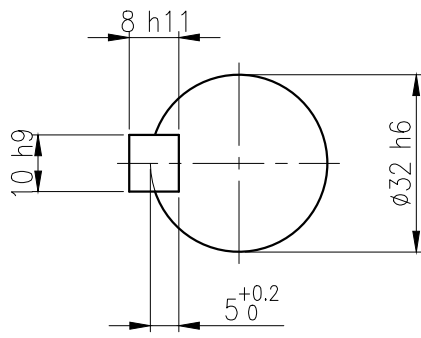
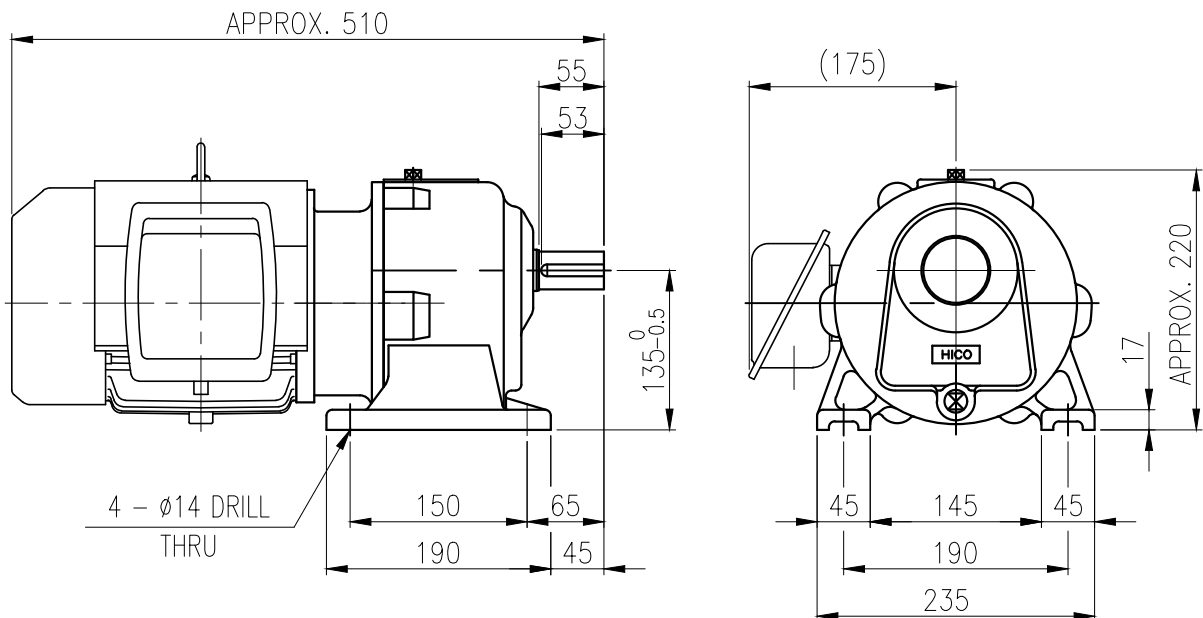

**OUTPUT SHAFT**  
KEY 10 x 8 x 48

		BEARING			
OIL SEAL		INPUT SHAFT	#6204ZZ	#6305ZZ	
MOTOR SHAFT D(M) 18x35x8		2ND PINION	#6301ZZ	#6302ZZ	GREASE : NLGI(EP)00
OUTPUT SHAFT D(M) 35x55x11		3RD PINION	#6303ZZ	#6304ZZ	ABOUT 0.5 kg
		OUTPUT SHAFT	#6307ZZ	#PM2025	WEIGHT 51 kg

		DWG NAME 외형도 OUTLINE DIMENSION							
		DWG No. <b>EK2DO07107W0001</b>		UNIT mm					
				SCALE 1:1					
No.	DATE	DESCRIPTION of REVISION		DESIGNED	CHECKED	REVIEWED	APPROVED	DATE	2018-08-15
A4(210X297mm)	FORM CE-14-0100-444 2013.11.20			2018.10.01	2018.10.01	2018.10.01	2018.10.01	REVISION No.	01
TYPE RPH_90Fr(1.5kW)_40~60:1_N type				최성민	문병선	박희성	홍원철	THIRD ANGLE PROJECTION	
		REF. No.	(EN245)					A	

The information written in this drawing is HYOSUNG HEAVY INDUSTRIES's property, and may not be disclosed and/or reproduced without the prior official permission of HYOSUNG HEAVY INDUSTRIES Corp.

이 도면에 표시된 정보는 호성중공업(주)의 소유이며 당사의 사전 서면동의 없이 무단사용을 금합니다.