

**OUTPUT SHAFT**

KEY 16 x 10 x 75

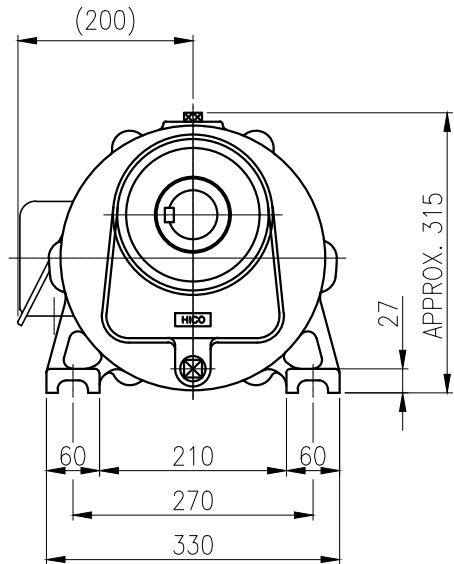
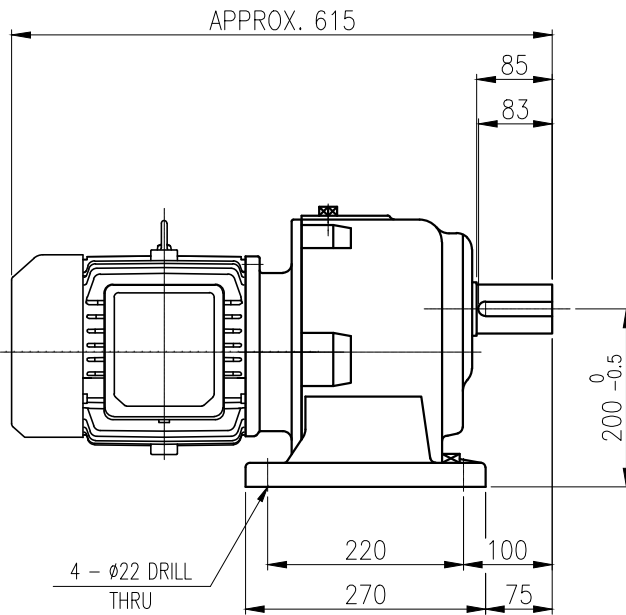

		BEARING			
OIL SEAL		INPUT SHAFT	#6205ZZ	#6306ZZ	
MOTOR SHAFT	D(M) 22x35x8	2ND PINION	#6304ZZ	#6305ZZ	GREASE : NLGI(EP)00
OUTPUT SHAFT	D(M) 60x82x12	3RD PINION	#6306ZZ	#5305ZZ	ABOUT 1.8 kg
		OUTPUT SHAFT	#6312ZZ	#PM4020	WEIGHT 115 kg

		DWG NAME				외형도 OUTLINE DIMENSION					
		DWG No. EK2D007113H001				UNIT	mm				
						SCALE	1:1				
No.	DATE	DESCRIPTION of REVISION				DESIGNED	CHECKED	REVIEWED	APPROVED	DATE	2018-08-15
A4(210x297mm)	FORM CE-14-0100-4A4 2013.11.20					2018.10.01	2018.10.01	2018.10.01	2018.10.01	REVISION No.	00
TYPE RPH_100Fr(2.2kW)_100~120:1_N type						최성민	문병선	박희성	홍원철	THIRD ANGLE PROJECTION	
		REF. No.	(EN275)						(A)		

이 도면상에 표시된 정보는 표상용이며 (단) 의 소유이며 영사의 사전 서면동의 없이 무단사용을 금합니다.