

VIEW "Q"

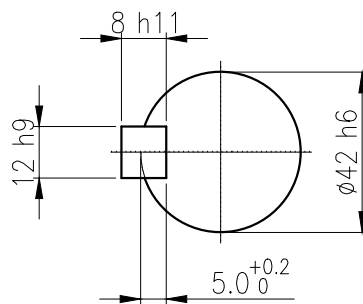

OUTPUT SHAFT

KEY 12 x 8 x 57

		BEARING			
OIL SEAL		INPUT SHAFT	#6203ZZ #6205ZZ	GREASE : NLGI(EP)00	
MOTOR SHAFT	D(M) 18x30x8	2ND PINION	#6302ZZ #6303ZZ	ABOUT	1.2 kg
OUTPUT SHAFT	D(M) 45x68x12	3RD PINION	#6303ZZ #6305ZZ	WEIGHT	62 kg
		OUTPUT SHAFT	#6309ZZ #PM3020		

		DWG NAME 외형도 OUTLINE DIMENSION			
		DWG No. EK2D007123W0001		UNIT	mm
				SCALE	1:1
No.	DATE	DESCRIPTION of REVISION			
		DESIGNED	CHECKED	REVIEWED	APPROVED
		2018.10.01	2018.10.01	2018.10.01	2018.10.01
		최성민	문병선	박희성	홍원철
		REVISION No.			01
		THIRD ANGLE PROJECTION			
TYPE RPV_80Fr(0.75kW)_100~120:1_N type		REF. No. (EN279)			(A)